



C.S. (WCB)

GATE VALVE

ASA 150#



AN ISO 9001 CERTIFIED CO.

Technical Specification :
Manufacturing Std. : API 600, BS 1414.
Testing & Inspection Std. : API 598.
Face to Face : As per ANSI B16.10
End Connections : Flanged as per ANSI B 16.5 RF.

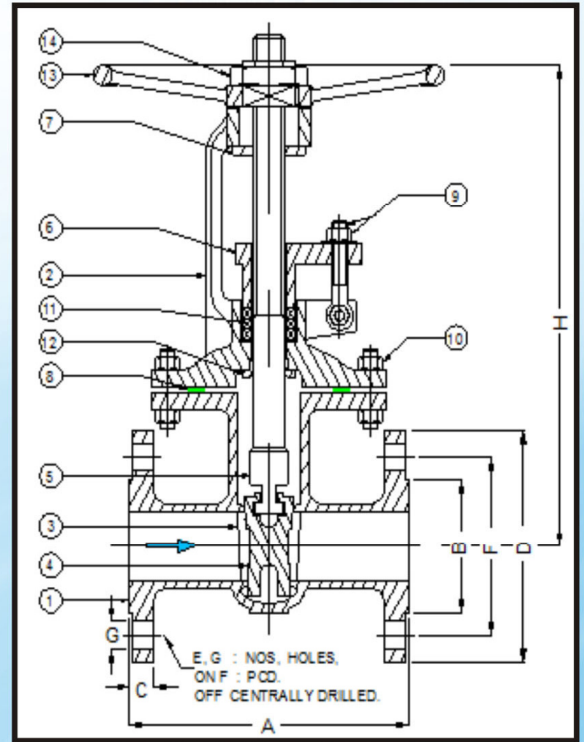

SR. NO.	NOMENCLATURE	MATERIAL
1	BODY	C.S. (ASTM A 216 Gr. WCB)
2	BONNET	C.S. (ASTM A 216 Gr. WCB)
3	SEAT RING	SS 410.
4	WEDGE	SS 410.
5	SPINDLE	SS 410.
6	GLAND FLANGE	C.S. (ASTM A 216 Gr. WCB)
7	YOKE NUT	M.S.
8	GASKET	GRAPHITE ASBESTOS / CAF.
9	EYE BOLT & NUT	CARBON STEEL.
10	STUD & NUT	ASTM A 193 Gr. B7 / 194 Gr. 2H.
11	GLAND PACKING	GRAPHOIL RING (GRAPHITE ASBESTOS).
12	BACK SEAT	SS 410.
13	HAND WHEEL	SG IRON.
14	HAND WHEEL NUT	M.S.

SERVICE RATING & TEST PRESSURE				
CLASS	WORKING PRESS.	TEMPERATURE (MAX)	HYD. TEST PRESS.	
			BODY	SEAT
150#	10KG/CM2	300 DEG. C.	28KG/CM2	20KG/CM2

SIZE		A FI TO FI	B (RF)	C	D (OD)	E No. of Hole	F (PCD)	G Hole Dia	H (Height)
INCH	M.M.								
1"	25	127	51	14	108	04	79	16	203
1.1/2"	40	165	73	14	127	04	98	16	254
2"	50	178	92	16	152	04	121	19	305
2.1/2"	65	191	105	17	178	04	140	19	343
3"	80	203	127	19	190	04	152	19	368
4"	100	229	157	24	229	08	190	19	406
5"	125	254	186	24	254	08	216	22	457
6"	150	267	216	25	280	08	241	22	559
8"	200	292	270	29	343	08	298	22	711
10"	250	330	324	30	406	12	362	25	914
12"	300	356	381	32	483	12	432	25	-
14"	350	381	413	35	533	12	477	28	-
16"	400	406	470	37	597	16	540	28	-

MFGR : -

VALSON VALVES MFG. CO. AHMEDABAD.

Visit us : - www.valsonvalves.com

All dimension are in M.M.